

Shift 2018

designed by Birger Garbe / Ulzburger Kites

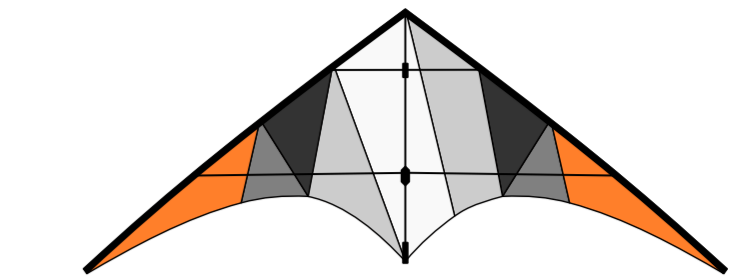

STD

leading edge	P200/P300	1500 mm
upper spreader	5mm	500 mm
lower spreader	BD Nitro	720 mm
spine	P200	~860 mm (~585 + ~275)
weight (brass)	6mm/80mm	~20 gr
inner standoff	3mm (glas)	265 mm (rod to sail)
outer standoff	3mm (carbon)	275 mm (rod to sail)

3-point bridle

upper outhaul	620 mm
outer outhaul	530 mm
inhaul	640 mm


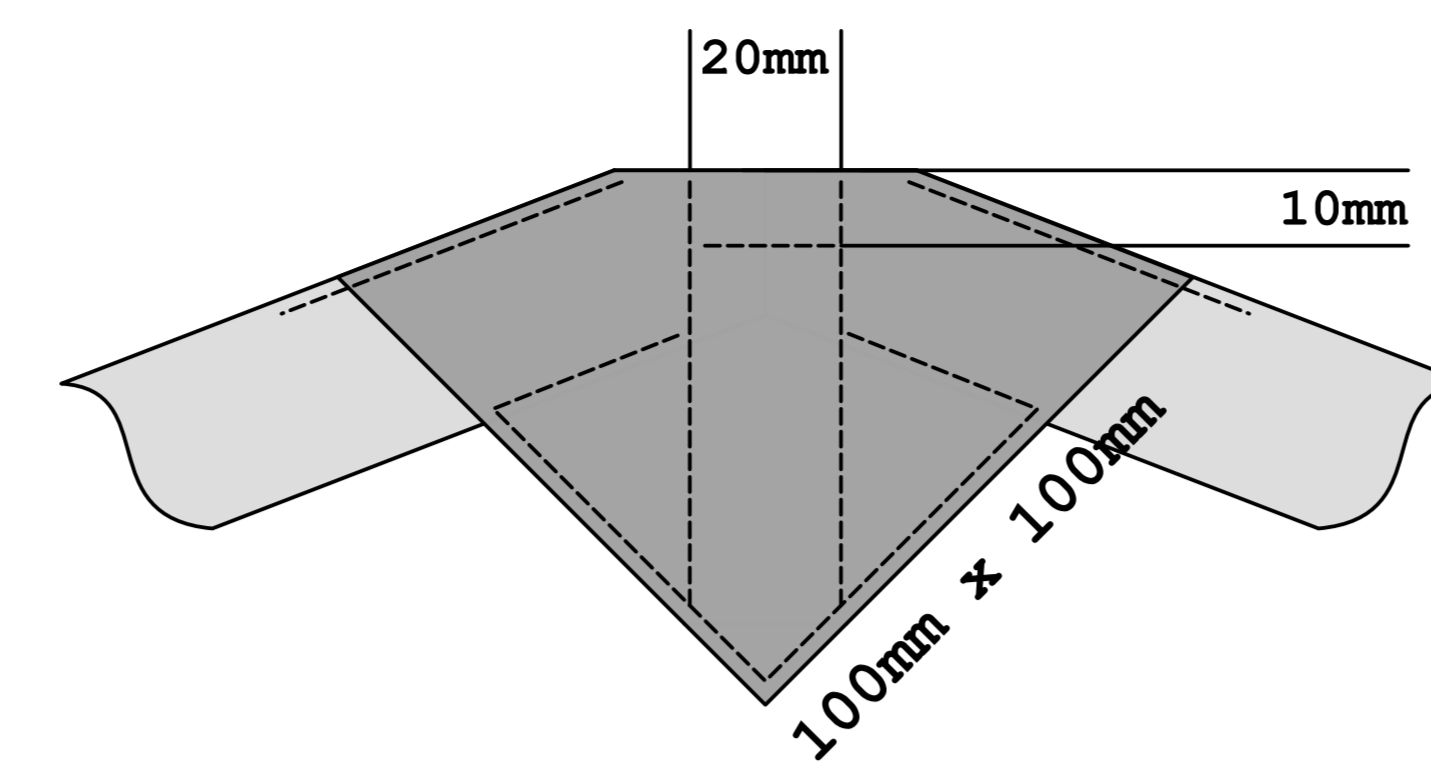

Shift

100mm x 100mm