

# Break XP 2023/07

designed by Birger Garbe / Ulzburger Kites  
refined by Stephan K. / SWP

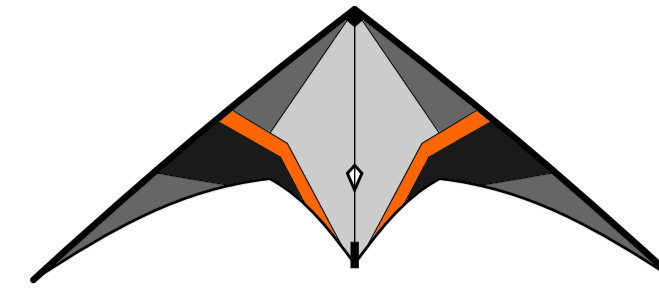

version XP

leading edge/upper	Penthalon Bandit 500 (7,0 gpi) ...	760 mm
leading edge/lower	Skylon Maverick 6.2 500 (7,7 gpi) ...	640 mm (*)
upper spreader	5mm	460 mm
lower spreader	SkyShark 5PT	650 mm
spine	Penthalon Bandit 400	790 mm
weight	6mm brass & split nock	12,5 gr
standoff	carbon 3mm	255 mm

(\*) if necessary shorten the rod depending on the assembly method of the split nock

3-point bridle		
upper outhaul	.....	490 mm
outer outhaul	.....	465 mm
inhaul	.....	555 mm

# Break 2022/11

designed by Birger Garbe / Ulzburger Kites

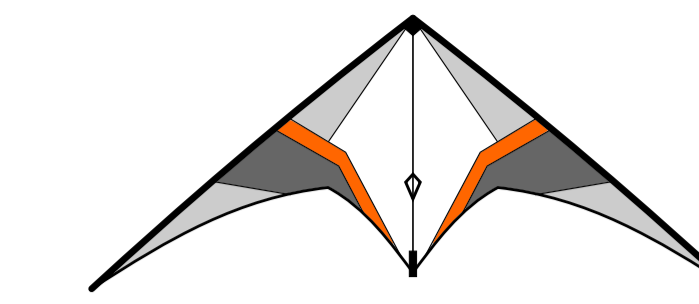

version STD

leading edge	DPP or Excel 6mm	.....	1400 mm
upper spreader	5mm	.....	460 mm
lower spreader	SkyShark 5PT	.....	650 mm
spine	Aurel Agil 400 or P200	.....	790 mm
weight (brass)	6mm/50mm	.....	12,5 gr
standoff	carbon 3mm	.....	255 mm (rod to sail)

3-point bridle		
upper outhaul	.....	520 mm
outer outhaul	.....	485 mm
inhaul	.....	585 mm

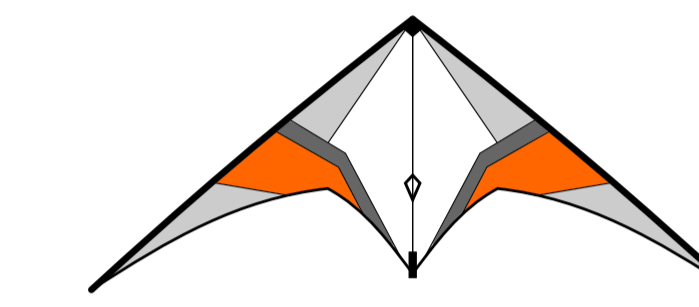

version LW

leading edge	DPP or Excel 5mm	.....	1400 mm
upper spreader	4mm	.....	460 mm
lower spreader	SkyShark 3PT	.....	650 mm
spine	Aurel Agil 600 or P100	.....	790 mm
weight (brass)	6mm/50mm	.....	12,5 gr
standoff	carbon 3mm	.....	255 mm (rod to sail)

3-point bridle		
upper outhaul	.....	520 mm
outer outhaul	.....	485 mm
inhaul	.....	585 mm

*[Break]*

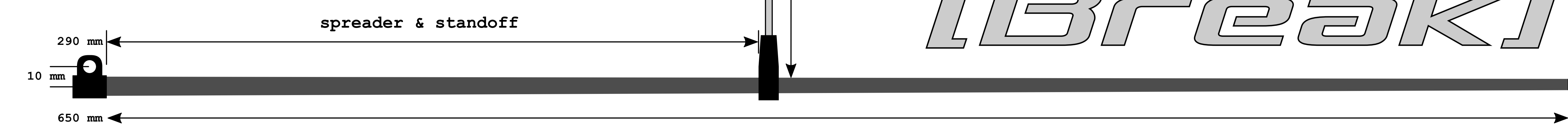
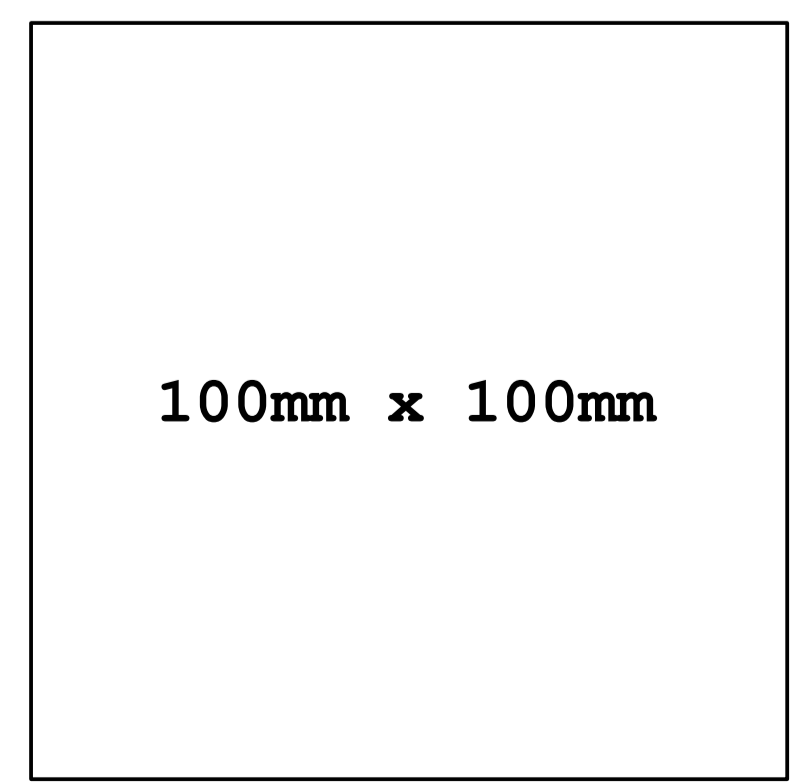

0 mm

205 mm

520 mm (cross)

565 mm (bridle)

1100 mm

1060 mm (bridle)

1050 mm (tiny APA)

1010 mm

820 mm (stopper)

560 mm

500 mm (APA)

450 mm (bridle)

430 mm

255 mm

0 mm

spreader & standoff

290 mm

10 mm

650 mm

100mm x 100mm